

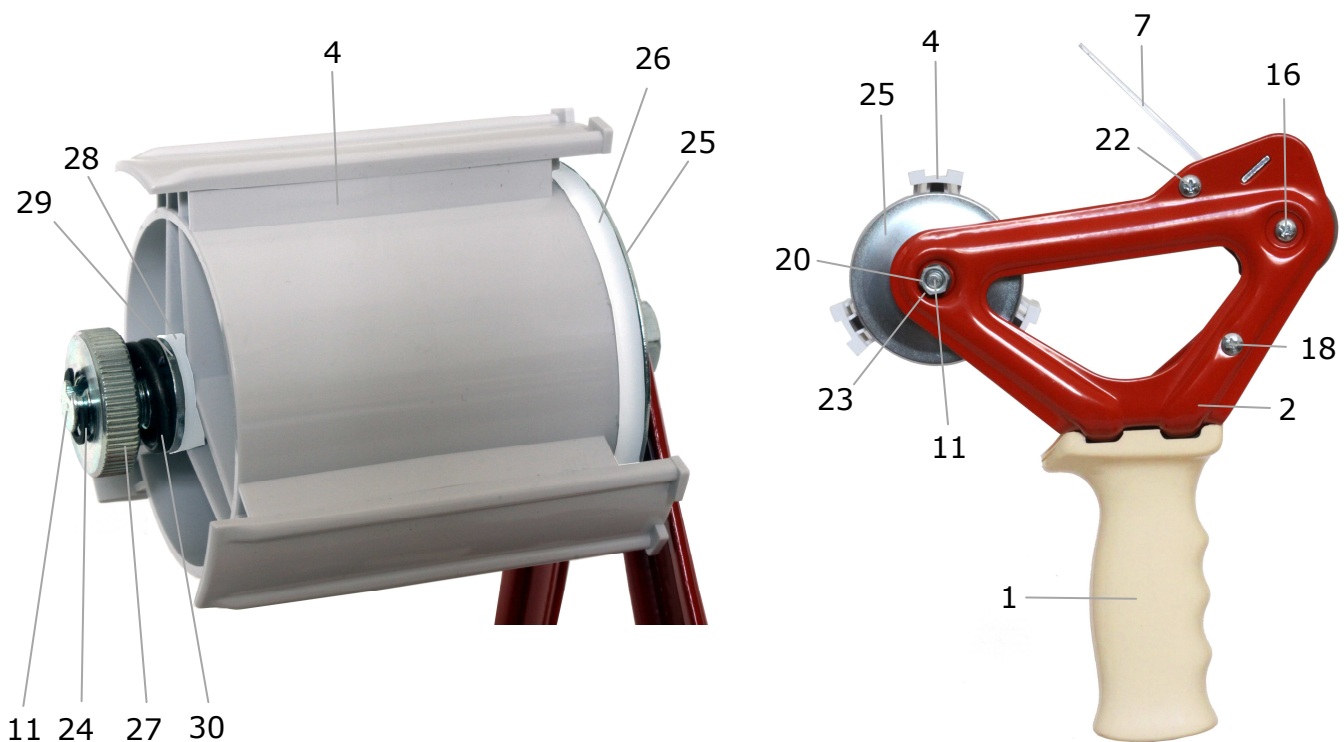

## Core holder



It is possible to order the core holder completely assembled. The code is 9 105 998 000

Ref	Article Code	Description	Weight Kg	Raw material / Treatments
1	9 105 001 000	Plastic handle T30R/75 #1	0,072	ABS plastic resin - Masterbatches to colour ABS resin -
2	9 105 002 000	Frame T30R/75 #2	0,224	Steel sheet 2,0 mm thickness - Pulver paint covered -
3	9 105 003 000	Frame extension T30R/75 #3	0,033	Steel sheet 2,0 mm thickness - Pulver paint covered -
4	9 105 041 000	Core holder T30R/75 AB #4	0,087	ABS plastic resin - Masterbatches to colour ABS resin -
5	9 105 005 000	Rubber roller T30R/75 #5	0,068	ABS plastic resin - SBS Thermoplastic rubber resin -
6	9 105 006 000	Tape locator plate T30R/75 #6	0,049	Steel sheet 1,5 mm thickness - Electrolytic Zinc plated -
7	9 105 007 000	Plastic pressure plate T30R/75 #7	0,017	Nylon Polyamide PA 6.6 glass fibre reinforced - Masterbatches to colour PA66F resin -
8	9 105 035 000	Waved blade T30R/75 #8	0,005	High carbon steel - Hardening process -
9	9 105 009 000	Blade support bar T30R/75 #9	0,038	Steel sheet 2,0 mm thickness - Electrolytic Zinc plated -

10	9 105 010 000	Spring plate T30R/75 #10	0,003	High carbon steel - Hardening process -
11	9 105 042 000	Core holder shaft T30R/75 AB #11	0,055	AVP steel - Electrolytic Zinc plated -
12	9 105 012 000	Shaft D 8 mm L 80 mm T30R/75 #12	0,027	AVP steel - Electrolytic Zinc plated -
13	9 105 013 000	Shaft D 8 mm L 80 mm T30R/75 #13	0,027	AVP steel - Electrolytic Zinc plated -
14	9 105 014 000	Flange screw Fe TE 8 MA x 32 T30R/75 #14	0,018	Steel - Electrolytic Zinc plated -
15	9 105 015 000	Shaft D 6 mm L 86,5mm T30R/75 #15	0,016	AVP steel - Electrolytic Zinc plated -
16	9 105 016 000	Screw Fe TC 5 MA x 10mm T30R/75 #16	0,002	Steel - Electrolytic Zinc plated -
17	9 105 017 000	Screw Fe TC 5 MA x 7mm T30R/75 #17	0,002	Steel - Electrolytic Zinc plated -
18	9 105 018 000	Screw Fe TGS 4 MA x 10 T30R/75 #18 DIN 7988	0,001	Steel - Electrolytic Zinc plated -
19	9 105 019 000	Flange exagonal nut 8 MA T30R/75 #19 UNI6923	0,007	Steel - Electrolytic Zinc plated -
20	9 105 020 000	Exagonal nut 8 MA H6,5 T30R/75 #20 UNI 5588	0,005	Steel - Electrolytic Zinc plated -
22	9 105 022 000	Screw Fe TC 5 MA x 10mm T30R/75 #22	0,002	Steel - Electrolytic Zinc plated -
23	9 105 023 000	Grower washer M 8 T30R/75 #23 UNI 1751	0,001	High carbon steel - Hardening process -
24	9 105 032 000	Circlip D 6 mm T30R/75 AB #24 DIN 6799	0,000	High carbon steel - Hardening process -
25	9 105 025 000	Metal brake disc T30R/75 AB #25	0,019	Steel sheet 0,8 mm thickness - Electrolytic Zinc plated -
26	9 105 026 000	Large nylon ring Brake T30R/75 AB #26	0,003	Nylon Polyamide PA 6 -
27	9 105 031 000	Knurled knob brake T30R/75 AB #27	0,010	AVP steel - Electrolytic Zinc plated -
28	9 105 028 000	Nylon washer T30R/75 AB #28	0,000	Nylon Polyamide PA 6 -
29	9 105 029 000	Steel washer D 18mm T30R/75 AB #29	0,002	Steel sheet 1,5 mm thickness - Electrolytic Zinc plated -
30	9 105 030 000	Helical spring brake T30R/75 AB #30	0,005	Spring steel -
998	9 105 998 000	Core holder T30R/75 AB #998 complete	0,175	

Updated : 26/04/2020